



Main

Range of Product	Modicon STB distributed I/O solution
Product or Component Type	EOS internal bus extension kit

Complementary

Kit composition	STBXBE1100 module STBXBA2400 size 2 base STBXTS2120, 2-terminal spring clamp connector STBXTS1120, 2-terminal screw type connector
Mounting Location	End of segment (except for the last segment)
Product Compatibility	Standard STB modules
Electrical connection	Firewire interface
Marking	CE
Oversvoltage category	II

Environment

Electromagnetic compatibility	Immunity to electromagnetic interference IEC 61131-2
Product Certifications	FM Class 1 Division 2 CSA UL
Pollution degree	2 IEC 60664-1
Operating altitude	<= 6561.68 ft (2000 m)
IP degree of protection	IP20 conforming to EN 61131-2 class 1
Ambient Air Temperature for Storage	-40...185 °F (-40...85 °C)
Relative humidity	95 % 140 °F (60 °C) without condensation
Vibration resistance	+/-0.35 mm 10...58 Hz 3 gn 58...150 Hz 35 x 7.5 mm symmetrical DIN rail 5 gn 58...150 Hz 35 x 15 mm symmetrical DIN rail
Shock resistance	30 gn 11 ms IEC 88 reference 2-27

Ordering and shipping details

Category	18215 - ADVANTYS STB I/O
Discount Schedule	PC32
GTIN	03595863949254
Nbr. of units in pkg.	1
Package weight(Lbs)	4.02 Oz (114 g)
Returnability	Yes
Country of origin	FR

Packing Units

Unit Type of Package 1	PCE
Package 1 Height	0.98 In (2.5 cm)
Package 1 width	3.15 In (8 cm)
Package 1 Length	5.12 In (13 cm)

Offer Sustainability

California proposition 65	WARNING: This product can expose you to chemicals including: Nickel compounds and Di-isodecyl phthalate (DIDP) which is known to the State of California to cause Carcinogen and Reproductive harm. For more information go to www.p65warnings.ca.gov
EU RoHS Directive	Pro-active compliance (Product out of EU RoHS legal scope) EU RoHS Declaration
Toxic heavy metal free	Yes
Mercury free	Yes
RoHS exemption information	Yes
China RoHS Regulation	China RoHS Declaration
Environmental Disclosure	Product Environmental Profile
Circularity Profile	End Of Life Information

Contractual warranty

Warranty	18 months
----------	-----------

Dimensions

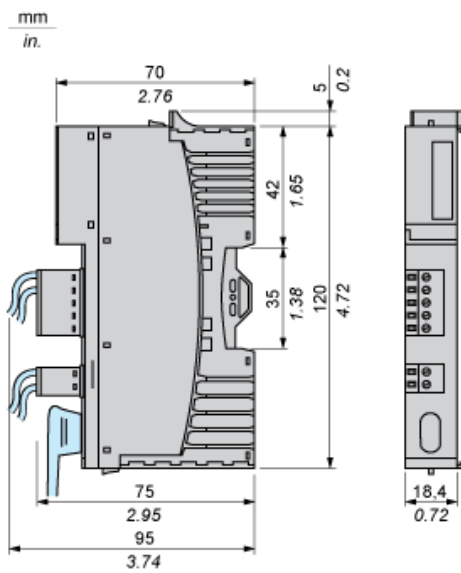

Product Life Status : Commercialised